

# 746 EMC

## **gearmotor** for sliding gates with max weight of 400 kg

available at AFW Access Systems

Phone: 305-691-7711 • Fax: 305-693-1386 • E-mail: sales@anchormiami.com • Web Site: AnchorMiami.com



### **IDEAL FOR RESIDENTIAL APPLICATIONS**

The control board inside the gearmotor facilitates and speeds up installation, at lower cost. Its compact size makes it ideal for residential applications with gates weighing up to 400 kg.

### **TOTALLY SAFE, RELIABLE IN ALL CONDITIONS**

Safety is guaranteed by the special, adjustable, oil-bath lubricated anti-crushing clutch, and by an intelligent electronic device which, when it detects the presence of an obstacle, reverses and stops gate movement. The FAAC 746 gearmotor performs uniformly, and all commands are supplied by an extremely safe and reliable microprocessor.

### **LONG LIFE**

Constant, complete oil-bath lubrication of mechanical components plus assembly in a high resistance pressure-cast aluminium body ensure a very long life.

### **IRREVERSIBLE**

As the gearmotor is non reversing, no electric locks need be installed and, in the event of power failure, the release device (protected by a customised key) makes it possible to open and close the gate manually.

### **746 EMC Z20 SPECIFICATIONS**

Non-reversing screw gearmotor • Gate max. weight 400 Kg • Gate speed 12 m/min • Max. use frequency 30% • Max thrust 50 daN • Electric motor power supply 230 V (+6% -10%) - 50 (60) Hz • Electric motor power 300 W • Thermal protection at 120°C built into motor winding • Operating ambient temperature -20°C +55°C • Protection class IP 44 • Lever operated release device with coded key • Single-phase motor with two rotation directions (1.400 rpm) • Pinion gear Z 20/module 4 • Inductive limit-switch • Lower and upper half-body in die-cast aluminium with cathaphoresis treatment • Twin-disk clutch in oil-bath • Anti-crushing safety to UNI 8612 standards • Opening/closing force adjustable by hexagonal key • Galvanised foundation plate with side and height adjustment (optional) • Dimensions (L x W x H) 275 x 191 x 312 (mm) • Built-in electronic card • ABS electronic card enclosure • Obstacle detection electronic sensor • 24 Vdc - 500 mA max. output for accessories • Microprocessor control • 2 protection fuses (motor/accessories) • Connector for card receiver/decoding cards • Separate high and low voltage terminal boards • Inputs status signalling LEDs • Programming Dip Switches • Braking control trimmer • Automatic (A1-A2) and semi-automatic (E1-E2) function logics • Two logics for safety devices (Dip Switches) • Selectable pause times 5-10-30-120 s (Dip Switches) • Selectable 5 s pre-flashing (Dip Switch) • Inputs: closing safety devices, stop push-button, total opening push-button and limit-switch • Outputs: power supply for accessories, motor, flashing lamp and indicator-light.



Model	Use	
	Max weight (kg)	Use frequency (%)
746 EMC Z20	400	30
746 EMC CAT	400	30
746 EMC RF	400	30

**INSTALLATION DIAGRAM SPECIMEN**

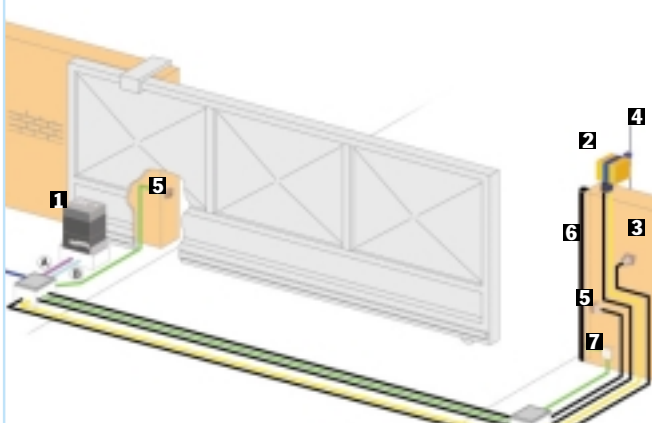

- 1 FAAC 746 Z20 with built-in control board/RP 433 DS
- 2 FAAC MINILAMP
- 3 FAAC T10 E
- 4 ANTENNA 433 MHZ
- 5 FAAC PHOTOBEAM
- 6 PNEUMATIC EDGE S 30
- 7 JUNCTION BOX with pressure switches

Low voltage cabling		Power cabling (230V)	
A	3 cables 3x0.5	B	1 cable 2x1.5+T
	2 cables 2x0.5		1 cable 2x1.5

N.B: Cable diameters in mm<sup>2</sup>

**Dimensions**

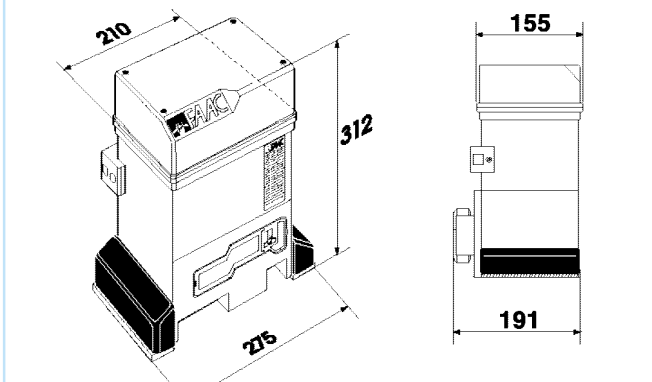

Values in mm



Technical specifications	746 EMC	Z20	CAT	RF
Power supply	230 V~ (+6% -10%) 50 (60) Hz			
Electric motor	Single-phase, bi-directional			
Absorbed power	300W			
Absorbed current	1.5 A			
Traction and thrust force	0÷50 daN			
Motor rotation speed	1.400 rpm			
Thermal protection on motor winding	120°C			
Clutch	Twin-disk in oil-bath			
Reduction ratio	1:30			
Operating ambient temperature	-20°C +55°C			
Weight with oil	14 kg			
Type of oil	FAAC oil XD 220			
Gate speed	12 m/min. (Z20)			
Protection class	IP 44			

Specifications of 746 MPS control board	
Power supply	230 V~ (+6% -10%) 50 (60) Hz
Motor maximum load	300W
Accessories output	24 Vdc 360 mA max
Operating ambient temperature	-20°C +55°C
Three protection fuses	0.25 A (SMT) transformer - 5 A motor - 0.5 A accessories

- **SMT Technology**
- **Programmable functions**
  - Four function logics A1/A2/E1/E2
  - Pause times
  - Pre-flashing
- **Braking control trimmer**
- **Inputs signalling LED and limit-switch**
- **Terminal board outputs**
  - Indicator-light, pre-flashing
- **Terminal board inputs**
  - Open, stop, safety devices
- **Rapid connectors for**
  - Motor, capacitor, limit-switch, card receivers/decoding cards
- **Reset push-button**
- **Obstacle detection electronic sensor**